



SERVICE PARTS LIST

BULLETIN NO.
54-05-0152

SPECIFY CATALOG NO. AND SERIAL NO. WHEN ORDERING PARTS		REVISED BULLETIN 54-05-0151	DATE Dec. '97
8 GALLON WET OR DRY VACUUM CLEANER			
CATALOG NO. 8950	SERIAL NUMBER	SERIES III	
WIRING INSTRUCTION			

EXAMPLE:
Component Parts (Small #) Are Included
When Ordering The Assembly (Large #).

00
0

FIG.	PART NO.	DESCRIPTION OF PART	NO. REQ.
1	31-15-0135	Housing Cap	(1)
2	23-66-0880	Switch	(1)
3	31-50-0490	Motor Housing	(1)
4	22-90-0145	Strain Relief Bushing	(1)
5	22-64-0136	Power Cord	(1)
6	06-95-5319	10 x 3/8 Ground Screw	(1)
7	06-97-3400	10 Split Lockwasher	(1)
8	43-44-0540	Motor Top Gasket	(1)
9		Motor (See Motor Housing Kit Below)	(1)
10	22-56-0160	Wire Connector	(3)
11	42-46-0100	Ball Float	(1)
12	31-15-0145	Plastic Cover Lid	(1)
13	49-90-0285	Cloth Filter	(1)
14	49-90-0770	Foam Sleeve	(1)
15	06-95-5390	10 x 2-3/4 Lg. Slit. H. H. Screw	(3)
16	06-95-5330	10 x 3/4 Lg. Slit. H. H. Screw	(4)
17	42-68-0410	Buckle	(4)
18	06-95-5315	10 x 1/2 Lg. Slit. H. H. Screw	(3)
19	31-44-0395	Handle Pkg. (2 Handle & Screws)	(1)
20	42-51-0385	Tank	(1)
21	42-86-0120	Inlet Fitting	(1)

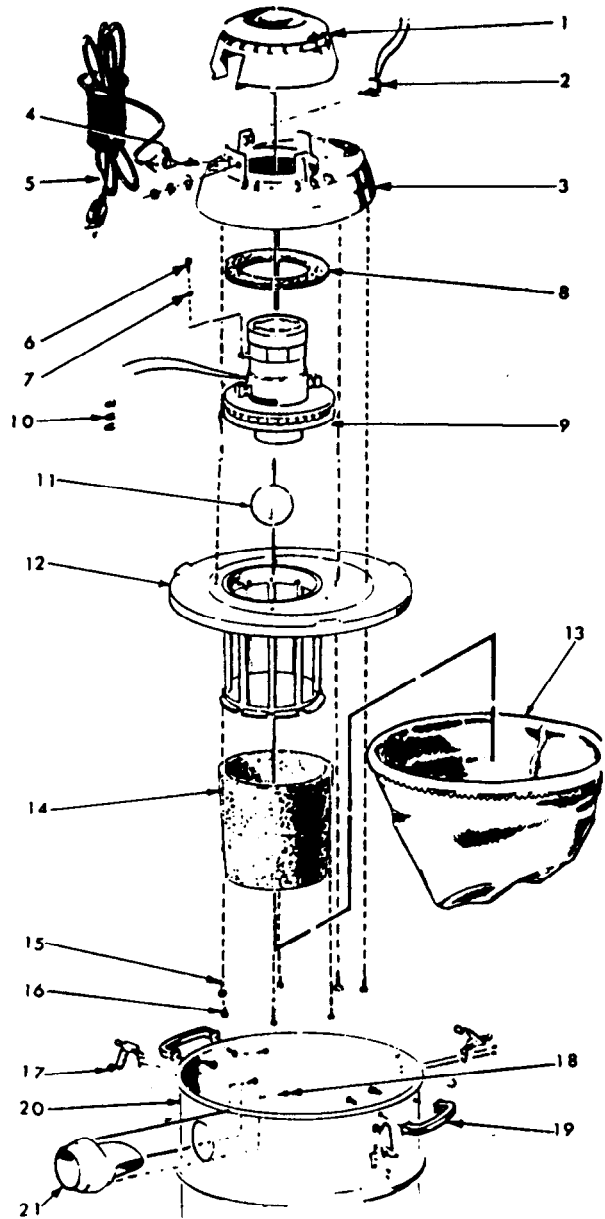

MOTOR HOUSING KIT 14-46-8950

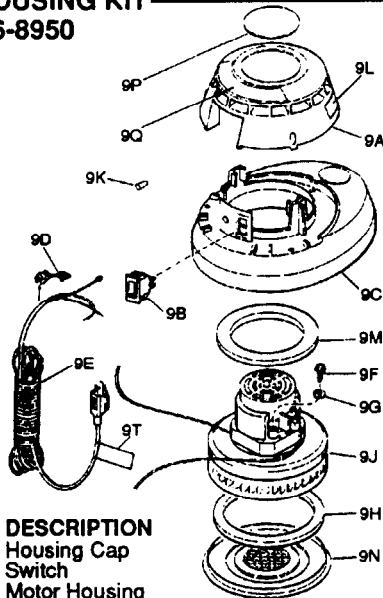

FIG.	PART NO.	DESCRIPTION	NO. REQ.
9A	31-15-0136	Housing Cap	(1)
9B	23-66-0885	Switch	(1)
9C	31-50-0181	Motor Housing	(1)
9D	22-90-0145	Strain Relief Bushing	(1)
9E	22-64-0137	Power Cord	(1)
9F	06-95-5319	#10 x 3/8" Slit. Hex Hd. Ground Screw	(1)
9G	06-97-3400	#10 Split Ring Lockwasher	(1)
9H	43-44-0555	Motor Bottom Gasket	(1)
9J	23-30-0165	Motor	(1)
9K	22-56-0160	Wire Connector	(3)
9L	12-20-8956	Service Nameplate Kit	(1)
9M	43-44-0540	Motor Top Gasket	(1)
9N	44-66-5365	Motor Plate	(1)
9P	10-20-8950	Warning Label	(1)
9Q	10-20-8955	French/Spanish Label	(1)
9R	06-95-5330	#10 x 3/4" Hex Hd. Screw (Not Shown)	(4)
9S	06-95-5391	#10 x 3" Hex Hd. Screw (Not Shown)	(3)
9T	10-15-1610	Warning Label	(1)

MILWAUKEE ELECTRIC TOOL CORPORATION
13135 W. LISBON RD., BROOKFIELD, WI 53005